

Specifications

Output Power HP (kW)	30 (22)
Phase	3 Phase
Pole	4 Pole
Frame Number	180M

Degrees of Protection	IP 55
Enclosure Construction	Totally-enclosed Fan-cooled
Thermal Class	Class F (155 °C)

Alignment	Horizontal
Frame Material	Cast Iron

Power Transmission	Direct-couple or Belt Driven
Direction of Rotation	Counterclockwise (CCW) viewed from shaft-end side



Connection Type	Lead Wire (6 Leads)
Coating Colour	Munsell N5.5 (Gray)
Conformed Standard	IEC 60034-1 & JEC-2137-2000



Voltage & Frequency	HT Type
	380~415V 50Hz
	380~440V 60Hz (suitable for γ - Δ starting)

* The perpendicular variation of tolerance for the shaft center is $\begin{matrix} 0 \\ -0.5 \end{matrix}$

Dimensions (mm)

Motor												
A	B	C*	D	E	F	G	H	I	J	JK	L	M
294.5	239	180	376	139.5	120.5	22	367	427	70	R6	646	350

Motor			Terminal Box			Shaft End						
N	XB	Z	KG	KD	KL	Q	QK	R	S	T	U	W
300	121	15	151	PF 1 1/2	295	110	90	351.5	48 k6	9	5.5	14

Bearing No.		Approximated Weight (kg)	Approximated Packing Dimensions (LxWxH)	Gross Weight (kg)
Drive End	Opposite			
6311ZZ	6310ZZ	195	814 x 651 x 548	219

Connection & Connection Diagram

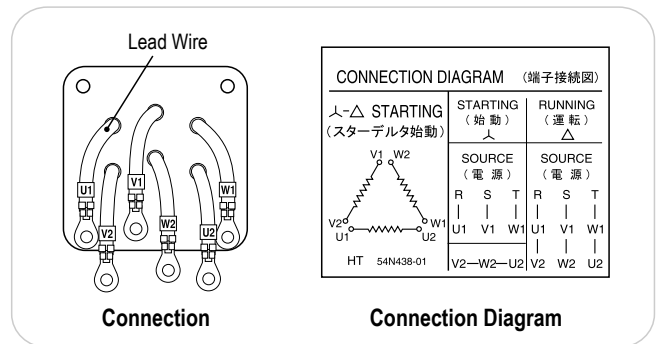

Circumstance Conditions

Ambient Temperature	-20 ~ +40°C
Ambient Humidity	95% RH or less
Operating Altitude	Less than 1,000m above sea level
Environment	No bursting / erosive gas or vapor

Motor Characteristics

Type	Hz	V	50% Load			75% Load			100% Load				Torque(%)		Is (A)	Inertia GD ² (kg-m ²)	
			(A)	Eff(%)	PF(%)	(A)	Eff(%)	PF(%)	(A)	Eff(%)	PF(%)	Speed (r/min)	Torque (kg-m)	Ts			Tm
HT	50	380	23.8	0.89	0.79	32.3	0.91	0.86	41.7	0.91	0.89	1460	14.68	267	263	281	0.71
		415	24.9	0.88	0.70	31.8	0.90	0.80	39.8	0.90	0.86	1470	14.58	324	320	307	
	60	380	22.0	0.90	0.85	31.0	0.91	0.89	40.8	0.91	0.91	1750	12.24	236	225	243	
		440	21.3	0.89	0.77	28.4	0.90	0.85	36.2	0.91	0.88	1760	12.18	320	304	282	